

zehnder

always the
best climate

Zehnder ComfoAir Q450 TR

Technical specification for comfort ventilation unit



General

Whether you are working on a new build or a renovation project: With a maximum air volume flow of 450 m³/h at an external pressure of 200 Pa, the Zehnder ComfoAir Q450 TR comfort ventilation unit is flexibly suitable for single-family houses and apartment buildings, offices and commercial buildings. With its new technologies, starting with the diamond heat exchanger, through the revolutionary fan technology for a modulating by-pass and the optional adaptive pre-heater, combined with state-of-the-art control system technology like flow control and active comfort control and a user-friendly operating concept from simple switches to apps, Zehnder ComfoAir Q is a guarantee for a comfortable, healthy and energy-efficient indoor climate.



Zehnder ComfoAir Q450 TR

* Depending on the control unit/sensor technology chosen. Detailed information on page 11 and at international.zehnder-systems.com



Zehnder ComfoSense C55



Zehnder ComfoSwitch C55



Zehnder ComfoControl

Benefits

- More heat recovery and less power consumption because of the diamond heat exchanger with a larger surface and lower pressure losses
- Silent and efficient operation via the latest fan technology with RadiCal impeller, flow ring and flow grid
- More comfort via optimal supply temperature via the modulating by-pass with an intelligent temperature controller
- Energy-saving and demand-oriented tempering of outdoor air via adaptive pre-heater (optional)
- Security for planning and installation as one unit combines right and left version
- Simple commissioning and quiet operation with perfectly balanced volume flows because of flow control technology
- User-friendly operation via the tailored operating concept: from an intelligent switch to the app
- Hygienic because of optimal filter concept with filter change wizard
- Avoidance of excessively dry room air because of humidity recovery with the Zehnder enthalpy exchanger (optional)

Technical specifications

Zehnder ComfoAir Q450 TR	
Max. air volume	450 m ³ /h
Height	809 mm
Total height	850 mm
Width	725 mm
Overall width	790 mm
Depth	570 mm
Total depth	580 mm / 595 mm
Weight	50 kg
Installation	Wall-mounted / floor-mounted
Temperature range	+7 °C to 40 °C in the installation room
Condensate drain	32 mm / DN 32 external thread
Nominal size of drain connection	160 mm
Supply voltage	230 V, 50 Hz
Power consumption without/with VEW	250 W / 2,240 W
Current draw without/with VEW	1.98 A / 10.80 A
Cos φ	0.32 – 0.57
Protection class	IP40
Housing	Sheet steel
Designer front panel	ABS, RAL 9003
Inner zone	EPP / ABS
Heat exchanger	PS
Enthalpy exchanger	PE-Copolymer



Energy figures

DIBt (preliminary data)		
Product	Zehnder ComfoAir Q450 TR	Zehnder ComfoAir Q450 TR enthalpy
Approval number	Pending (file number III58-1.51.3-29/16)	Pending (file number III58-1.51.3-29/16)
Extract air volume flow V_{ab} [m ³ /h]	$50 \leq V_{ab} \leq 450^*$	$50 \leq V_{ab} \leq 450^*$
Heat recovery efficiency η_{WRG} [-]	93%*	82%*
Specific electric power consumption p_{el} [W/(m ³ /h)]	0.20*	0.18*

"Passivhaus" certification

Component ID	0954vs03	1007vs03
Application [m ³ /h]	70-345	70-345
Heat recovery efficiency η_{WRG} [-]	88%	83%
Specific electric power consumption $p_{el,spec}$ [W/(m ³ /h)]	0.21	0.21
Humidity recovery η_X [-]	-	71%

EU Energy Consumption Label

Energy efficiency class		
Maximum air volume flow [m ³ /h]	450	450
Sound power level L_{WA} [dB]	45	45

* uncorrected manufacturer's specifications

** depending on the control unit/sensor technology chosen.

Article numbers

TR = rotating connectors; Enthalpy = enthalpy exchanger

Comfort ventilation unit	Article number
ComfoAir Q450 TR	471 502 112
ComfoAir Q450 TR enthalpy	471 502 113

Accessories	Article number
ComfoAir Q350/450/600 pre-heater	400 502 007
ComfoAir Q350/450/600 mounting base	471 502 008
Dry siphon 5/4"	990 201 330
Enthalpy exchanger for ComfoAir Q350/450/600	527 006 990

Filters	Article number
Filter set for ComfoAir Q350/450/600, G4 / G4 (contains 2 units)	400 502 012
Filter set for ComfoAir Q350/450/600, G4 / G7 (contains 2 units)	400 502 013
Filter set for ComfoAir Q350/450/600, G4 / G4 (contains 10 units)	400 502 014
Filter set for ComfoAir Q350/450/600, G4 / G7 (contains 10 units)	400 502 015

Control units	Article number
ComfoSense C55 control panel	655 010 225
ComfoSense C67 control panel	655 010 235
ComfoSwitch C55 control panel	655 010 245
ComfoSwitch C67 control panel	655 010 255
ComfoConnect LAN C interface	655 011 100
ComfoConnect KNX C interface	655 011 120
ComfoAir Q350/450/600 option box	471 502 007
CO ₂ sensor	659 000 340
Humidity sensor	659 000 330
Remote-controlled control panel*	655 000 755
ComfoSplitter	655 010 270

* only in conjunction with a ComfoSense C control panel

System expansions	Article number
Zehnder ComfoFond-L Q L TR brine-earth heat exchanger, supply air connection left	471 310 082
Zehnder ComfoFond-L Q R TR brine-earth heat exchanger, supply air connection right	471 310 083

Technologies

Diamond heat exchanger



Unique, ultra-powerful heat exchanger – for maximum energy efficiency

The Paul diamond heat exchanger features an especially large surface, which allows it to achieve a higher level of efficiency. Variable duct heights ensure even flow and lower pressure losses, and thus optimal airflow. As a result, less energy is required to overcome the air resistance.

Fans

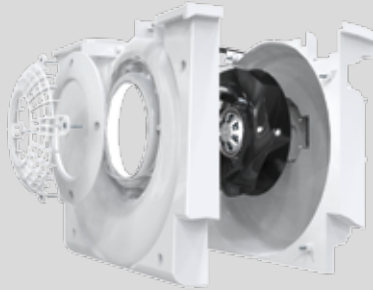

State-of-the-art fan technology – for quiet, energy-saving operation

The flow grid, scroll housing and ebm-papst RadiCal impeller ensure the best possible air flow. This guarantees not only extremely quiet operation, but also particularly low power consumption. A high-quality, future-proof solution, based on tried-and-tested technology.

Modulating by-pass

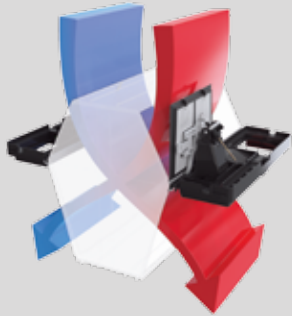

Comfortable indoor ventilation because of intelligent control of the heat recovery

The by-pass controls the exact degree of heat recovery and influences the supply air temperature as a result. The modulating by-pass is guided by an optimum comfort temperature, which is determined on the basis of information from the temperature and humidity sensors as well as an intelligent algorithm.

Pre-heater

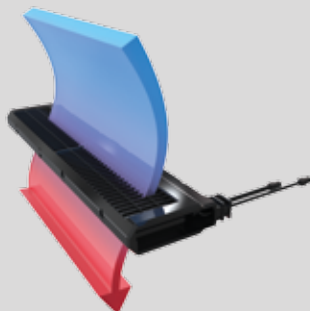

Intelligent temperature control of the drawn-in outdoor air for the best possible energy efficiency

The adaptive pre-heater adapts perfectly to the temperature, volume flow and air humidity, and provides the outside air temperature required for energy-efficient operation no matter what the temperatures are outside. The level of pressure loss is negligible because of its large surface and delta shape – and that also reduces the power consumption.

Sensors

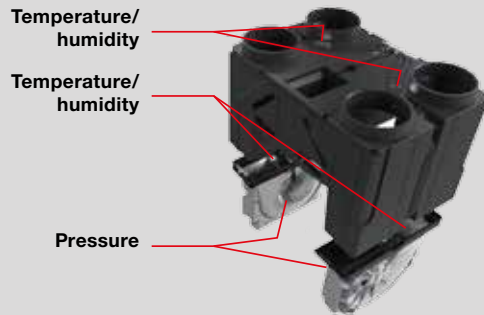

Flawless operation because of intelligent control

Individual sensors continuously determine the temperature, humidity and air pressure in the comfort ventilation unit. This permits precise control of the modulating by-pass, the pre-heater, flow control and humidity comfort mode. The sensors permit precise control of the ventilation unit for a perfect feel-good climate.

Comfort temperature

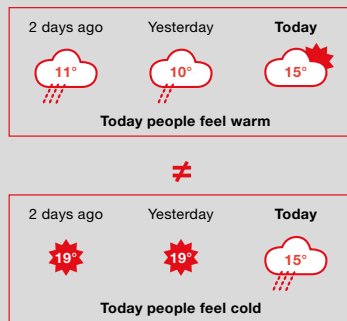

Ideal supply air temperature because of comfort technology

People's temperature sensation depends on the current outdoor temperature and the average outdoor temperatures experienced recently. For this reason, the adaptive climate technology in Zehnder ComfoAir Q adapts the supply air temperature to suit their current needs. As a result, Zehnder ventilation units make an important contribution to ensuring a comfortable indoor climate throughout the year – benefiting your customers.

Filters



Optimum hygiene because of powerful filters

Completely sealed and maximised, the filters prevent dust from getting into the room air. There is also a warning indicator to show when it is time to replace the filters, ensuring the air is always clean and healthy. The indicator factors in not only the elapsed time, but also the air volume transported.

Flow control



Innovative air volume balancing for maximum heat recovery

New and patented: innovative sensor technology automatically ensures balanced supply air and extract air volumes. This flow control guarantees maximum heat recovery. What's more, you save time during commissioning because there is no need to adjust the speed manually and the air volumes are balanced automatically.

Control options

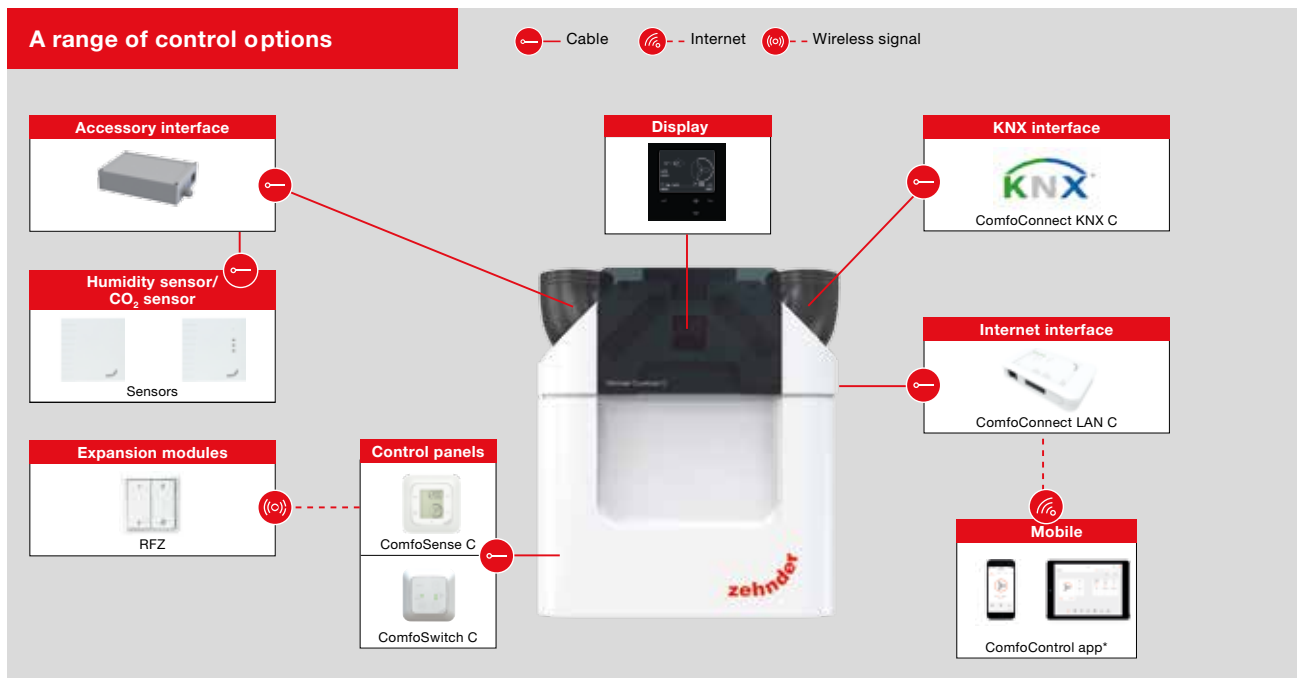

Control panel	Description	Article number	Accessories required
Unit display	Display integrated ex works	-	-
External control panels	ComfoSense C55 control panel ComfoSense C67 control panel ComfoSwitch C55 control panel ComfoSwitch C67 control panel	655 010 225 655 010 235 655 010 245 655 010 255	-
Wireless remote control	Wireless remote control RF	655 000 755	ComfoSense C control panel
Sensor (wired, 0 - 10 V control output)	CO ₂ sensor Humidity sensor	659 000 340 659 000 330	Option box
App control and web portal	ComfoConnect LAN C interface	655 011 100	Internet access + router with WiFi access
Connection to KNX network	ComfoConnect KNX C interface	655 011 120	

All components can be combined with one another. If there are more than four components, a Zehnder ComfoSplitter is required.

* Internet access and a router with WiFi access are required for connection

Control functions

Comfort ventilation unit

- Commissioning wizard
- Filter change wizard
- Real time information for energy saving/consumption
- Adaptive comfort temperature control
- Flow control technology, constant volume and constant speed control
- 4 levels, party and absence settings
- Weekly time schedule
- Control for a modulating electric preheater
- Supply and extract air can be set and deactivated separately
- Frost protection function
- Programme setting: fire place
- ComfoCool Q600 control (Q600 only)

Option box

- Control for ComfoFond-L Q brine-earth heat exchanger
- Power-on and power-off delay for bathroom switch
- Control for re-heater 0-10 V
- Demand control (CO₂ sensor, humidity sensor)

Tender specification

Zehnder ComfoAir Q450 TR ventilation unit with integrated display

The Zehnder ComfoAir Q450 TR is a centralised, compact ventilation unit with heat recovery and integrated adaptive summer by-pass. This ventilation unit is ideal for new builds as well as for renovation projects.

The housing, made of galvanised or painted sheet steel, is acoustically and thermally insulated. Economical DC fans with RadiCal impeller, flow ring and flow grid ensure economical operation and therefore permit a high level of electrical efficiency. Supply and extraction fans can be controlled separately and can be precisely adjusted to within one percent by entering the balance air volume.

The core of Zehnder ComfoAir Q450 TR is the plastic cross-counterflow heat exchanger with up to 95% heat recovery. The unit is operated via the integrated control panel. Optionally, it can be operated via a wired control panel (ComfoSense C or ComfoSwitch C), which is connected to the ventilation unit with a cable provided on site (JYSTY 2x2x0.6). It can also be operated via the Zehnder ComfoConnect LAN C or ComfoConnect KNX C interfaces. All working conditions and error messages can be read from the display.

Zehnder ComfoAir Q450 TR is delivered ready to plug in and use. The filters can be replaced easily from the front by the user without opening the unit. The Zehnder ComfoAir Q450 TR can be either with wall-mounted or floor-mounted with an optionally available base. It is connected via 4 rotating DN 160 connectors at the top of the unit or on the side.

- Automatic frost protection regulation - Filter replacement display
- G4/ F7 filters
- Automatic and temperature-controlled by-pass
- Fault history including the last three error messages
- Supply and extraction fans can be activated separately
- Comfort temperature controller
- Programme setting: fire place
- Heat exchanger: PE-Copolymer
- Fans: EC DC fans, radial, suction side
- Filter:
 - Extract air: G4
 - Outdoor air: F7
- Condensate drain: DN 32
- Air duct connections: 4x DN160 on top or at the side, freely rotating
- Mains power supply: 230 V, 50 Hz
- Temperature range: 7 °C to 40 °C in the installation room
- Sound power (min./max.):
 - Extract air: 42.0 dB(A) / 53.0 dB(A)
 - Supply air: 52.0 dB(A) / 70.0 dB(A)
- Waste heat recovery efficiency: up to 93%
- Volume flow:
 - max. 450 m³/h at 200 Pa external
 - min. 40 m³/h at 10 Pa external
- Power consumption:
 - Maximum 175 watt
- Electrical efficiency:
 - 0.2 Wh/m³ at 315 m³/h
- Dimensions:
 - Height: with connector 850 mm
 - Width: with connector on top 775 mm, at side 789 mm
 - Depth: 570 mm
- Type: ZE ComfoAir Q450 TR ventilation unit with integrated display
- Brand: Zehnder Comfosystems
- Article number: 471 502 112

Sound specifications

Sound, pressure side (supply air/exhaust air)*

Measurement point	[m ³ /h]	[Pa]	63 Hz [dB]	125 Hz [dB]	250 Hz [dB]	500 Hz [dB]	1,000 Hz [dB]	2,000 Hz [dB]	4,000 Hz [dB]	8,000 Hz [dB]	Total [dB(A)]
1	200	25	62.5	57.5	58.0	47.8	44.1	41.0	32.4	18.4	52.5
2	250	50	65.2	60.2	60.6	52.2	47.4	44.7	37.2	24.2	55.7
3	300	50	67.2	62.2	62.4	55.5	49.8	47.5	40.7	28.5	58.1
4	315	50	67.8	62.8	63.0	56.5	50.6	48.3	41.8	29.8	58.9
5	350	100	70.2	65.2	65.3	60.4	53.5	51.6	46.0	34.9	61.9
6	400	100	72.2	67.2	67.1	63.6	55.9	54.3	49.5	39.1	64.5
7	450	100	74.2	69.2	69.1	66.9	58.4	57.1	53.1	43.5	67.3
8	350	150	71.1	66.1	66.2	61.9	54.7	52.9	47.7	36.9	63.2
9	350	200	72.1	67.1	67.1	63.4	55.8	54.2	49.4	39.0	64.4
10	400	200	73.8	68.8	68.7	66.3	58.0	56.6	52.5	42.7	66.8
11	450	200	75.7	69.8	69.6	67.8	59.1	57.9	54.2	44.8	69.3

Sound, suction side (extract air/outdoor air)*

Measurement point	[m ³ /h]	[Pa]	63 Hz [dB]	125 Hz [dB]	250 Hz [dB]	500 Hz [dB]	1,000 Hz [dB]	2,000 Hz [dB]	4,000 Hz [dB]	8,000 Hz [dB]	Total [dB(A)]
1	200	25	50.6	45.6	50.1	35.1	24.1	19.1	14.4	17.9	42.4
2	250	50	53.3	48.3	51.6	38.8	27.4	22.9	17.9	18.5	44.2
3	300	50	55.2	50.2	52.7	41.4	29.8	25.7	20.4	18.9	45.7
4	315	50	55.8	50.8	53.0	42.3	30.5	26.6	21.2	19.0	46.2
5	350	100	58.2	53.2	54.3	45.5	33.4	30.0	24.3	19.4	48.1
6	400	100	60.1	55.1	55.4	48.1	35.8	32.8	26.8	19.8	49.8
7	450	100	62.1	57.1	56.5	50.9	38.2	35.7	29.4	20.2	51.7
8	350	150	59.1	54.1	54.8	46.7	34.5	31.3	25.5	19.6	48.9
9	350	200	60.0	55.0	55.3	48.0	35.7	32.7	26.7	19.8	49.8
10	400	200	61.7	56.7	56.3	50.4	37.8	35.1	28.9	20.2	51.4
11	450	200	63.6	58.6	57.3	52.8	40.0	37.7	31.3	20.5	53.2

Housing radiation, installation room*

Measurement point	[m ³ /h]	[Pa]	63 Hz [dB]	125 Hz [dB]	250 Hz [dB]	500 Hz [dB]	1,000 Hz [dB]	2,000 Hz [dB]	4,000 Hz [dB]	8,000 Hz [dB]	Total [dB(A)]
1	200	25	44.1	39.1	44.4	35.4	30.9	30.3	20.1	15.5	39.3
2	250	50	47.3	42.3	46.6	38.9	34.4	34.1	24.9	19.0	42.4
3	300	50	49.7	44.7	48.2	41.5	36.9	37.0	28.5	21.7	44.7
4	315	50	50.4	45.4	48.7	42.3	37.7	37.8	29.5	22.5	45.4
5	350	100	53.2	48.2	50.7	45.5	40.8	41.2	33.8	25.6	48.3
6	400	100	55.5	50.5	52.3	48.0	43.3	44.0	37.3	28.2	50.8
7	450	100	57.9	52.9	54.0	50.7	45.9	46.9	40.8	30.8	53.4
8	350	150	54.3	49.3	51.5	46.7	42.0	42.5	35.4	26.8	49.5
9	350	200	55.4	50.4	52.3	47.9	43.2	43.9	37.1	28.1	50.7
10	400	200	57.5	52.5	53.7	50.2	45.5	46.3	40.2	30.3	52.9
11	450	140	59.7	54.7	55.2	52.6	47.8	48.9	43.5	32.8	55.3

* Housing radiation measured per ISO 3741:2010
 Noise, suction side/pressure side, measured per ISO 5135:1997
 Lw in dB(A) at reference area 10⁻¹² W

Performance values

Performance data*								
Measurement point	[m ³ /h]	[Pa]	P [W]	cos φ	SFP [Wh/m ³]	Lw, pressure side [dB(A)]	Lw, suction side [dB(A)]	Lw, housing [dB(A)]
1	200	25	23	0.44	0.11	52	42	39
2	250	50	44	0.48	0.17	56	44	42
3	300	50	62	0.50	0.21	58	46	45
4	315	50	69	0.51	0.22	59	46	45
5	350	100	101	0.53	0.29	62	48	48
6	400	100	129	0.55	0.32	64	50	51
7	450	100	160	0.36	0.34	67	52	53
8	350	150	117	0.54	0.33	63	49	49
9	350	200	133	0.55	0.38	64	50	51
10	400	200	162	0.56	0.41	67	51	53
11	450	140	196	0.57	0.44	69	53	55

* SFP in Wh/m³ calculated per EN13141-7:2010
cos phi with pre-heater deactivated

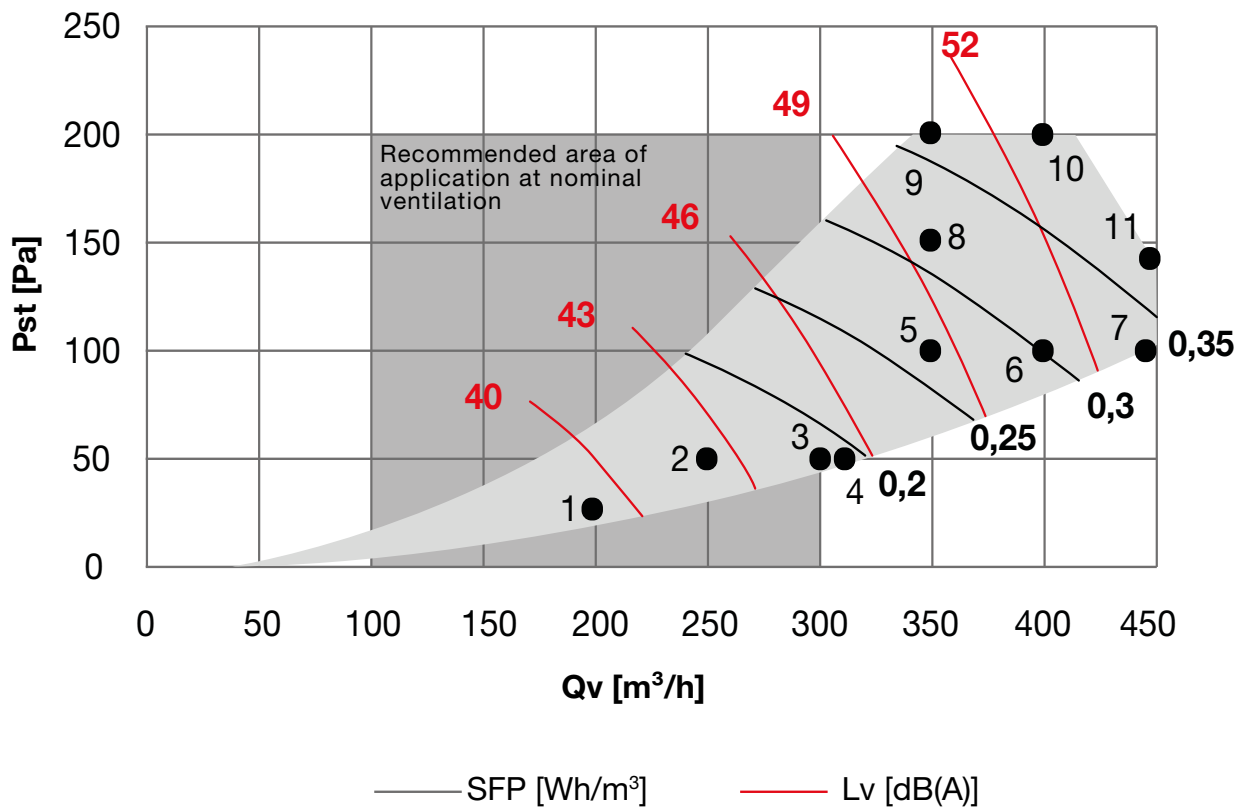

Dimensional drawings

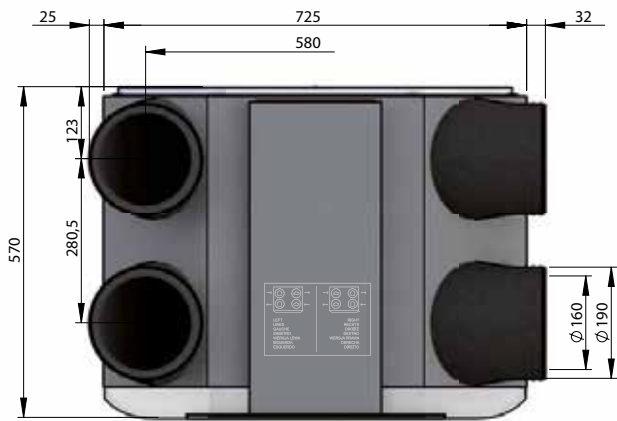

Top

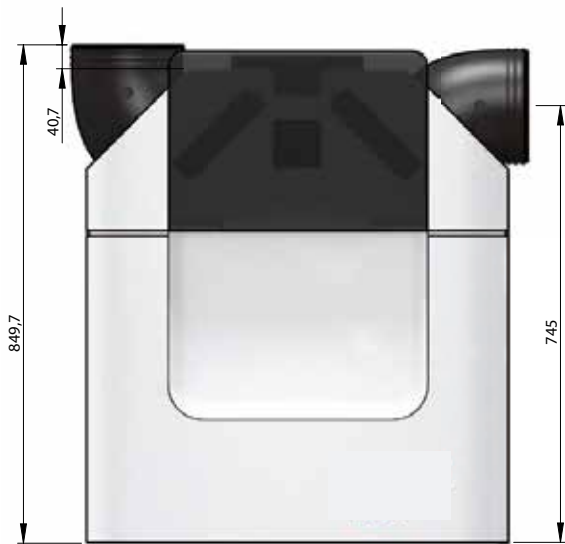

Front

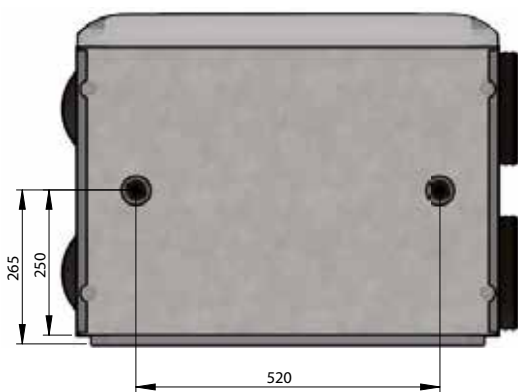

Bottom

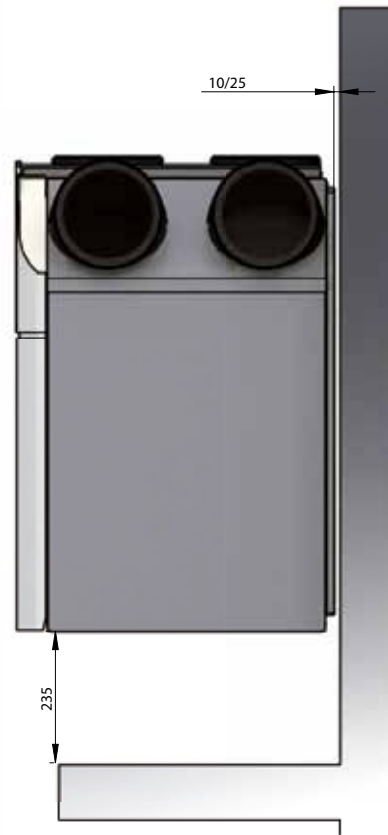

Side

Air directions

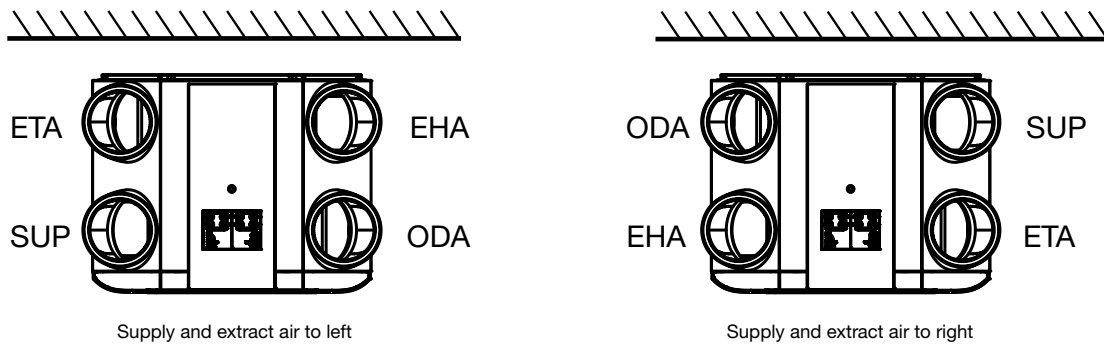

Energy efficiency classes

Energy efficiency classes in accordance with EU Regulation no. 1254/2014.

Energy efficiency classes

	Article number	Control according to site requirements			Central demand control	Time control	Manual control
		2 x CO ₂ sensor 659 000 340	Option Box 471 502 007 + 1 x CO ₂ sensor 659 000 340 and 1 x humidity sensor 659 000 330	2 x humidity sensor 659 000 330	No further accessories	No further accessories	No further accessories
ComfoAir Q450 TR	471 502 112	A⁺			A⁺	A	A
ComfoAir Q450 TR enthalpy	471 502 113	A⁺			A	A	A

Release data: 25/01/2017

Information requirement for RVUs as per EU Regulation No. 1254/2014												
Heat recovery unit Zehnder ComfoAir Q450												
Supplier's name or trade mark	Zehnder Group			Zehnder Group			Zehnder Group			Zehnder Group		
Supplier's model identifier	ComfoAir Q450			ComfoAir Q450			ComfoAir Q450			ComfoAir Q450		
SEC [kWh/(m ² a)] specific energy consumption (cold, average, warm)	-80,0	-40,7	-15,5	-80,7	-41,2	-16,0	-82,3	-42,6	-17,2	-84,8	-44,7	-19,1
SEC Class	A+	A	E	A+	A	E	A+	A+	E	A+	A+	E
Type of ventilation unit	Bidirectional RVU			Bidirectional RVU			Bidirectional RVU			Bidirectional RVU		
Type of drive installed	Multi-speed drive			Multi-speed drive			Variable speed drive			Variable speed drive		
Type of heat recovery system	Recuperative			Recuperative			Recuperative			Recuperative		
Thermal efficiency [%]	93			93			93			93		
Maximum flow rate [m ³ /h]	450			450			450			450		
Electric power input [W]	245			245			245			245		
Sound power level [dB(A)]	45			45			45			45		
Reference flow rate [m ³ /h]	315			315			315			315		
Reference pressure difference [Pa]	50			50			50			50		
SPI [W/(m ³ /h)]	0,18			0,18			0,18			0,18		
Control factor and typology	1 Manual control			0,95 Clock-controlled			0,85 Central demand control			0,65 Local demand control		
Declared maximum internal and external leakage rates [%]	Internal: 0,6			Internal: 0,6			Internal: 0,6			Internal: 0,6		
	External: 1,1			External: 1,1			External: 1,1			External: 1,1		
Mixing rate	-			-			-			-		
Position and description of visual filter warning	Warning on the display of the unit or room controller			Warning on the display of the unit or room controller			Warning on the display of the unit or room controller			Warning on the display of the unit or room controller		
Internet address for assembly and disassembly instructions	www.international.zehnder-systems.com			www.international.zehnder-systems.com			www.international.zehnder-systems.com			www.international.zehnder-systems.com		
Airflow sensitivity to pressure variations [%]	-			-			-			-		
Indoor/outdoor air tightness [m ³ /h]	-			-			-			-		
AEC [kWh/a] annual electricity consumption (cold, average, warm)	808	271	226	791	254	209	745	208	163	677	140	95
AHS [kWh/a] annual heating energy saved (cold, average, warm)	9150	4678	2115	9172	4689	2120	9216	4711	2130	9303	4756	2150

Information requirement for RVUs as per EU Regulation No. 1254/2014												
Heat recovery unit Zehnder ComfoAir Q450 ERV												
Supplier's name or trade mark	Zehnder Group			Zehnder Group			Zehnder Group			Zehnder Group		
Supplier's model identifier	ComfoAir Q450 ERV			ComfoAir Q450 ERV			ComfoAir Q450 ERV			ComfoAir Q450 ERV		
SEC [kWh/(m ² a)] specific energy consumption (cold, average, warm)	-73,8	-37,8	-14,6	-74,8	-38,5	-15,1	-76,9	-40,1	-16,3	-80,6	-42,7	-18,4
SEC Class	A+	A	E	A+	A	E	A+	A	E	A+	A+	E
Type of ventilation unit	Bidirectional RVU			Bidirectional RVU			Bidirectional RVU			Bidirectional RVU		
Type of drive installed	Multi-speed drive			Multi-speed drive			Variable speed drive			Variable speed drive		
Type of heat recovery system	Recuperative			Recuperative			Recuperative			Recuperative		
Thermal efficiency [%]	82			82			82			82		
Maximum flow rate [m ³ /h]	450			450			450			450		
Electric power input [W]	245			245			245			245		
Sound power level [dB(A)]	45			45			45			45		
Reference flow rate [m ³ /h]	315			315			315			315		
Reference pressure difference [Pa]	50			50			50			50		
SPI [W/(m ³ /h)]	0,16			0,16			0,16			0,16		
Control factor and typology	1 Manual control			0,95 Clock-controlled			0,85 Central demand control			0,65 Local demand control		
Declared maximum internal and external leakage rates [%]	Internal: 1,6			Internal: 1,6			Internal: 1,6			Internal: 1,6		
	External: 1,1			External: 1,1			External: 1,1			External: 1,1		
Mixing rate	-			-			-			-		
Position and description of visual filter warning	Warning on the display of the unit or room controller			Warning on the display of the unit or room controller			Warning on the display of the unit or room controller			Warning on the display of the unit or room controller		
Internet address for assembly and disassembly instructions	www.international.zehnder-systems.com			www.international.zehnder-systems.com			www.international.zehnder-systems.com			www.international.zehnder-systems.com		
Airflow sensitivity to pressure variations [%]	-			-			-			-		
Indoor/outdoor air tightness [m ³ /h]	-			-			-			-		
AEC [kWh/a] annual electricity consumption (cold, average, warm)	782	245	200	768	231	186	727	190	145	667	130	85
AHS [kWh/a] annual heating energy saved (cold, average, warm)	8465	4327	1957	8521	4356	1970	8633	4413	1996	8858	4528	2047

Z_SI_V0317_CSX_TES_TS136, en, subject to change without notice